

Enable secure access for remote work with Airwall

Support remote work with secure, encrypted access from anywhere in the world

“Tempered was able to deliver secure remote access for our company anywhere in the world. They provided us a cost-effective solution that was less complex to build, manage, and secure.”

VP of Information Security & CISO @ Global Five Star Casino Resort

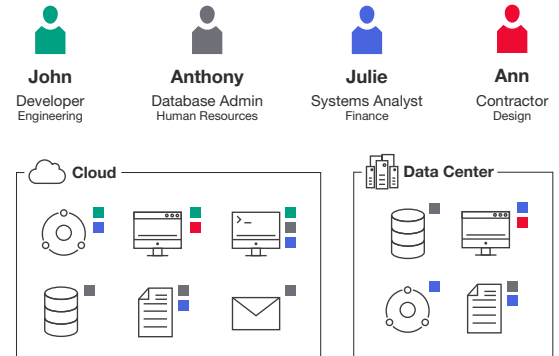

Challenge: scaling, securing, and managing remote access is difficult

Effectively scaling, securing and managing remote work is difficult with existing solutions. Traditional tactics of maintaining VPNs, ACLs, routing rules, and firewall policies, become increasingly difficult when large portions of your workforce move to remote work.

This becomes even more challenging when you need to provide access to critical infrastructure and systems. Corporate networks with hardened perimeter security were designed with on-prem work in mind. In these situations, enabling remote work with traditional remote access solutions can inherently weaken a corporate network's existing security perimeter.

Solution: easily enable secure remote access at scale

Tempered's Airwall Solution enables secure, encrypted access from anywhere in the world. Simply and easily segment access to company resources for your entire workforce, while ensuring PCI, HIPAA, and NIST compliance.

Airwall only allows access between mutually authenticated and authorized machines. Every device is given explicit access to specific network assets. With Airwall, group users so that

they are invisible to others by default, and grant access to specific devices or resources as appropriate.

With point-and-click simplicity, add or revoke access between devices on your network without the complexity of ACLs, routing rules, or firewall policies. Connect any ‘thing’ to anything anywhere, securely and easily.

Tempered’s Airwall Solution provides total security and mobility for your entire workforce, wherever they are and for whatever they need to reach—globally.

Airwall Solution benefits

- Protect sensitive data and intellectual property
- Support your organization’s existing security posture
- No need for rip-and-replace or wholesale network upgrades
- Easily add/revoke network access
- Maintain PCI, HIPAA, and NIST compliance

Secure access reference architecture

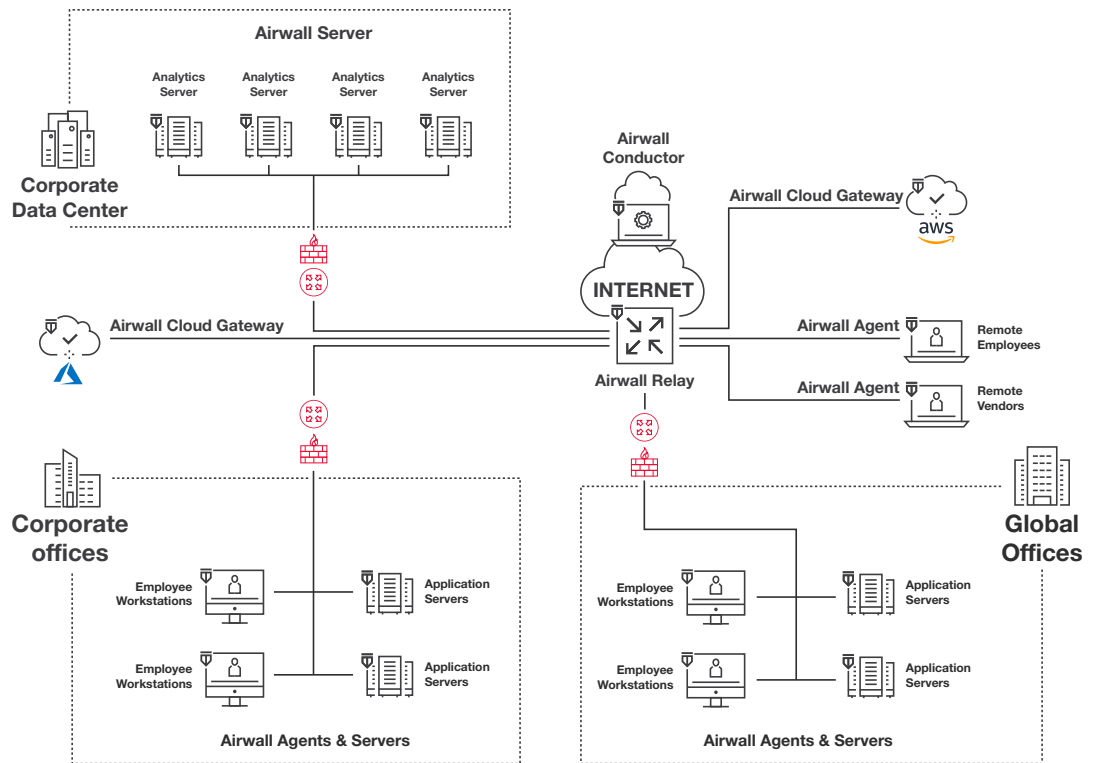

Schedule a call with experts to learn more.

IMPRES Technology Solutions Inc.
10330 Pioneer Blvd., Suite 280
Santa Fe Springs, CA 90670
(562) 298-4030 info@imprestechology.com



www.imprestechology.com/csoi